

2 OPERATION

Section	Page
2.1 DDEC BENEFITS	2-3
2.2 FEATURES	2-3
2.3 DDEC SYSTEM—HOW IT WORKS	2-4
2.4 DDEC RELATED PUBLICATIONS	2-17



2.1 DDEC BENEFITS

All Detroit Diesel On-Highway engines come standard with Detroit Diesel Electronic Controls (DDEC®). The state of the art Electronic Control Module (ECM) allows precise control of the engine management system that provides:

- Excellent engine performance
- Optimum fuel economy
- Emissions to meet current laws without after treatment
- Engine diagnostics
- Simple programming

2.2 FEATURES

The following features are part of the DDEC system:

- Engine Protection System
- Cruise Control
- Cruise Power
- Cruise Control Automatic Resume
- Progressive Engine Braking In Cruise Control
- Fan Controls
- Engine Fan Braking
- Progressive Shifting
- Vehicle Speed Limiting
- Vehicle Overspeed Diagnostics
- Vehicle ID Number
- Pressure Governor
- Starter Lockout
- Remote Throttle - PTO - Control
- High Idle Controls
- DDEC Ether Start
- Optimized Idle
- Idle Adjustment
- Idle Timer Shutdown
- Air Temperature Shutdown
- Auxiliary Engine Protection
- Customer Password
- Rating Security
- Maximum Security
- Low DDEC Voltage Light
- Low Coolant Light

- Low Oil Pressure Light
- High Oil Temperature Light
- High Coolant Temperature Light
- De-acceleration Light
- 12-volt or 24-volt ECM
- Communications Links SAE J1587, J1922, J1939

2.3 DDEC SYSTEM—HOW IT WORKS

The major components of the DDEC system consist of the electronic control module (ECM), the electronic unit injectors (EUI) and the various system sensors. The purpose of the sensors is to provide information to the ECM regarding various engine performance characteristics. The information sent to the ECM is used to instantaneously regulate engine and vehicle performance.

2.3.1 Electronic Unit Injector

An electronic unit injector incorporates a solenoid operated poppet valve which performs the injection timing and metering functions. When the solenoid valve is closed, pressurization and fuel injection is initiated. Opening the solenoid valve releases injection pressure, ending injection. The duration of valve closure determines the quantity of fuel injected. See Figure 2-1.

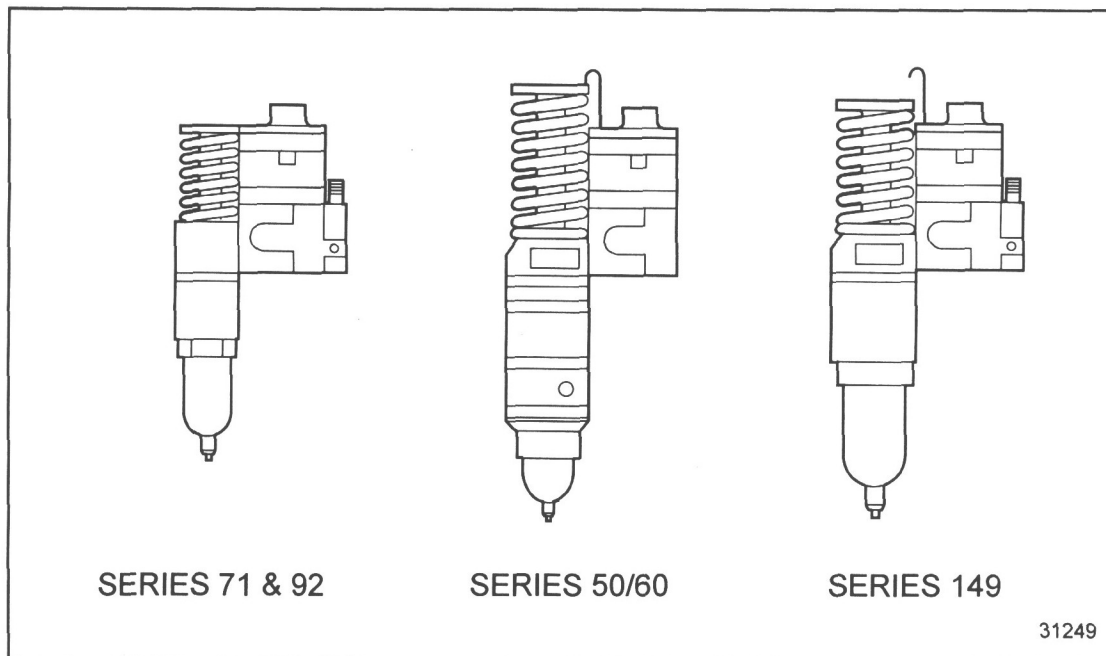

Figure 2-1 Electronic Unit Injector

2.3.2 Electrical Connectors

Provide water-tight connections for the harnesses between the sensors and the ECM.

2.3.3 Air Temperature Sensor

The air temperature sensor is located in the air intake manifold and monitors the air temperature entering the engine. The ECM adjusts the engine timing to reduce white smoke, improve cold starts, and provide engine protection. See Figure 2-2.

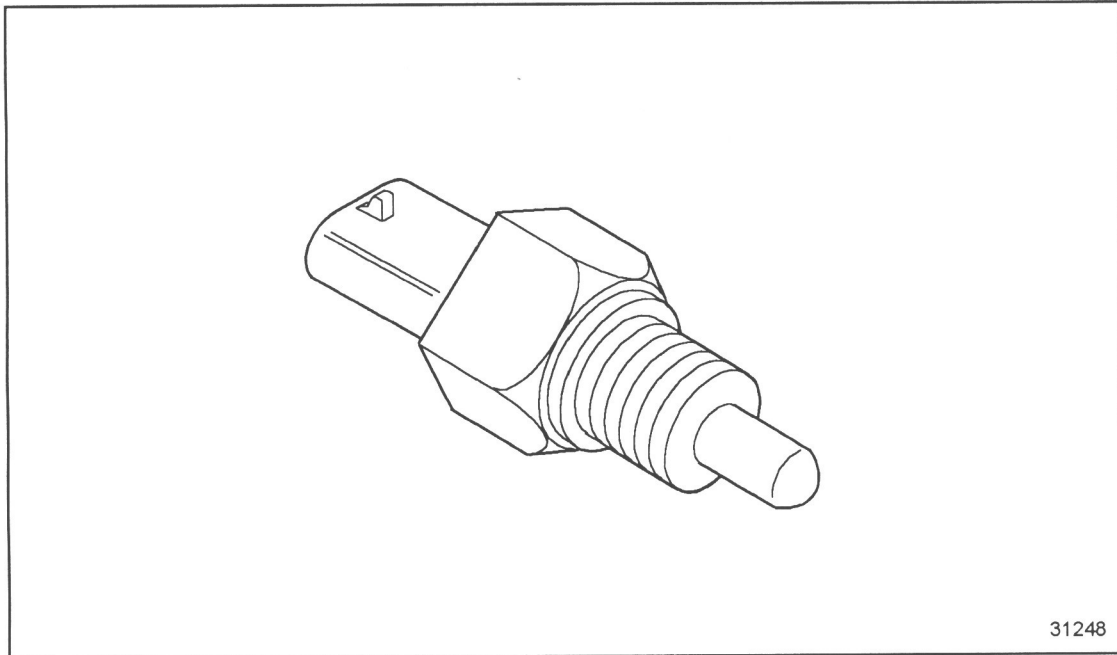

Figure 2-2 Air Temperature Sensor

2.3.4 Coolant Temperature Sensor

The coolant temperature sensor is located on the right side of the engine. The engine protection feature will be triggered if the coolant temperature exceeds the specified limits. See Figure 2-3.

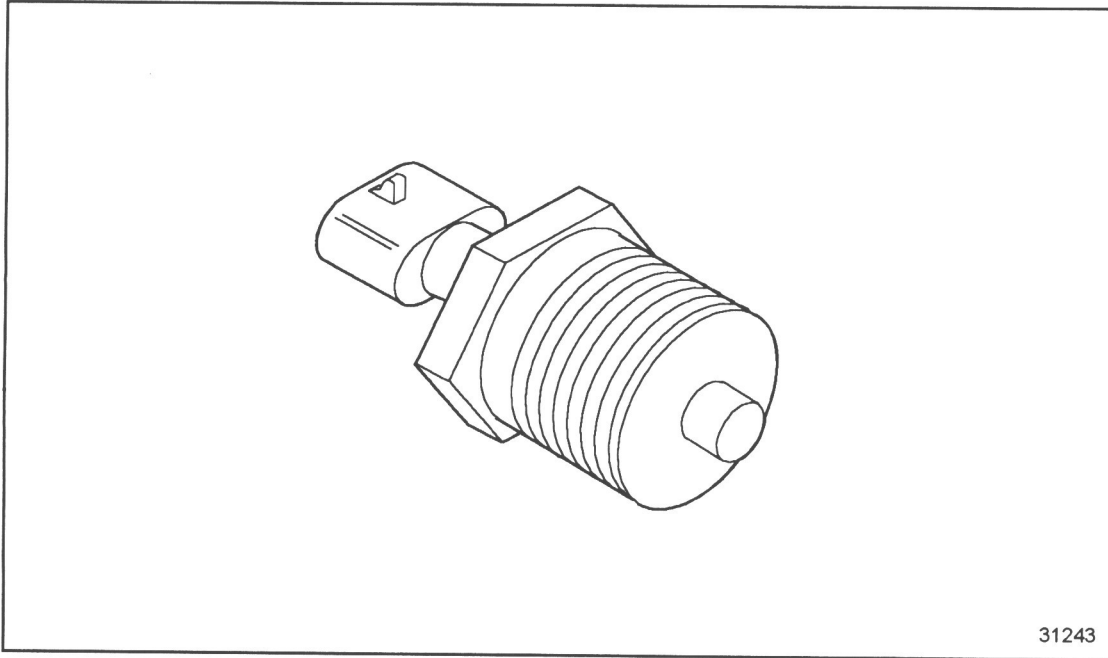

Figure 2-3 Coolant Temperature Sensor

2.3.5 Fire Truck Pump Pressure Sensor

The fire truck pump pressure sensor is used to monitor water pressure for the Pressure Governor System in the DDEC system. The signal back to the ECM changes r/min which allows the fire truck water pump to maintain a steady water pressure during pumping operation in fire trucks. See Figure 2-4.

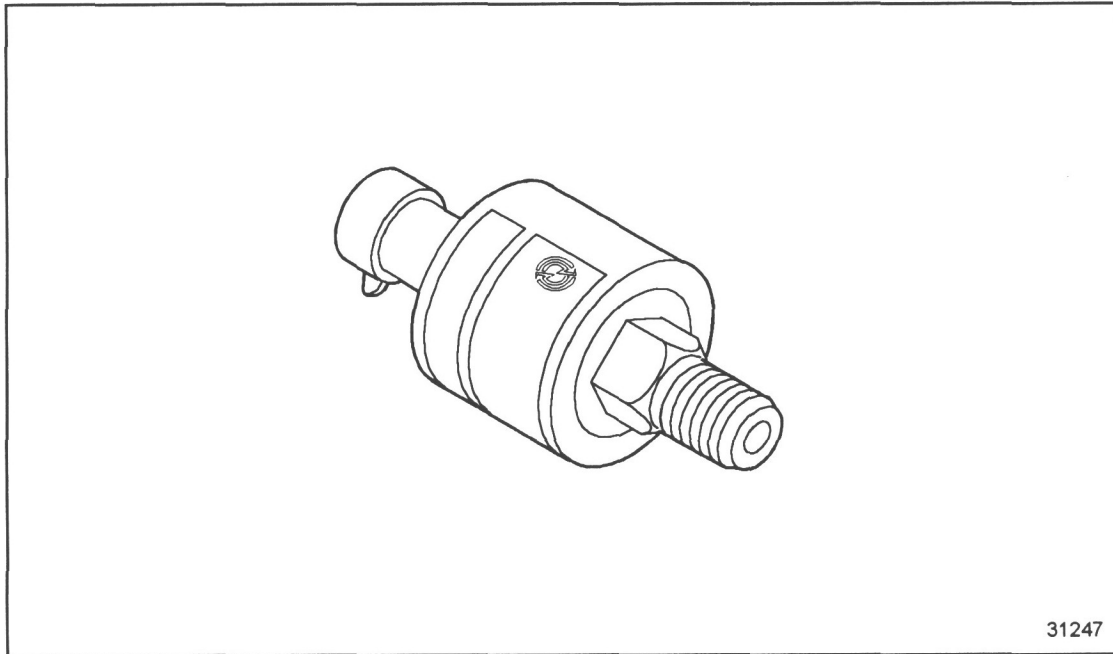

Figure 2-4 Fire Truck Pump Pressure Sensor

2.3.6 The Synchronous Reference Sensor and Timing Reference Sensor

These sensors control the timing of the engine. The SRS sensor provides a “once per cam revolution” signal and the TRS sensor provides a “36 per crankshaft revolution” signal. Working together, these sensors tell the ECM which cylinder is at top-dead-center for cylinder firing. Precise monitoring of piston position allows for optimum injection timing, resulting in excellent fuel economy and performance with low emissions. See Figure 2-5 for the SRS and the TRS.

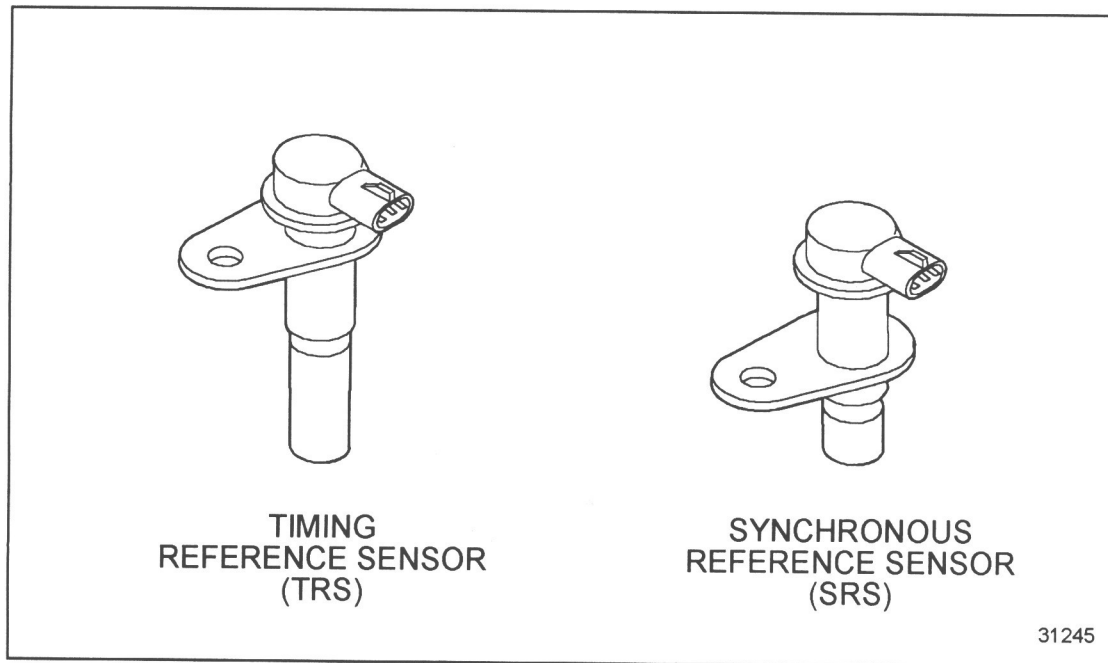

Figure 2-5 Timing Reference Sensor and Synchronous Reference Sensor

2.3.7 Oil and Fuel Temperature Sensors

The oil temperature sensor optimizes idle speed and injection timing to improve cold startability and reduce white smoke. This sensor will activate the engine protection system if the oil temperature is higher than normal.

The fuel temperature sensor provides a signal to the ECM. The ECM utilizes the fuel temperature signal to adjust the fueling for changes in the fuel density as a function of temperature to maintain horsepower. See Figure 2-6.

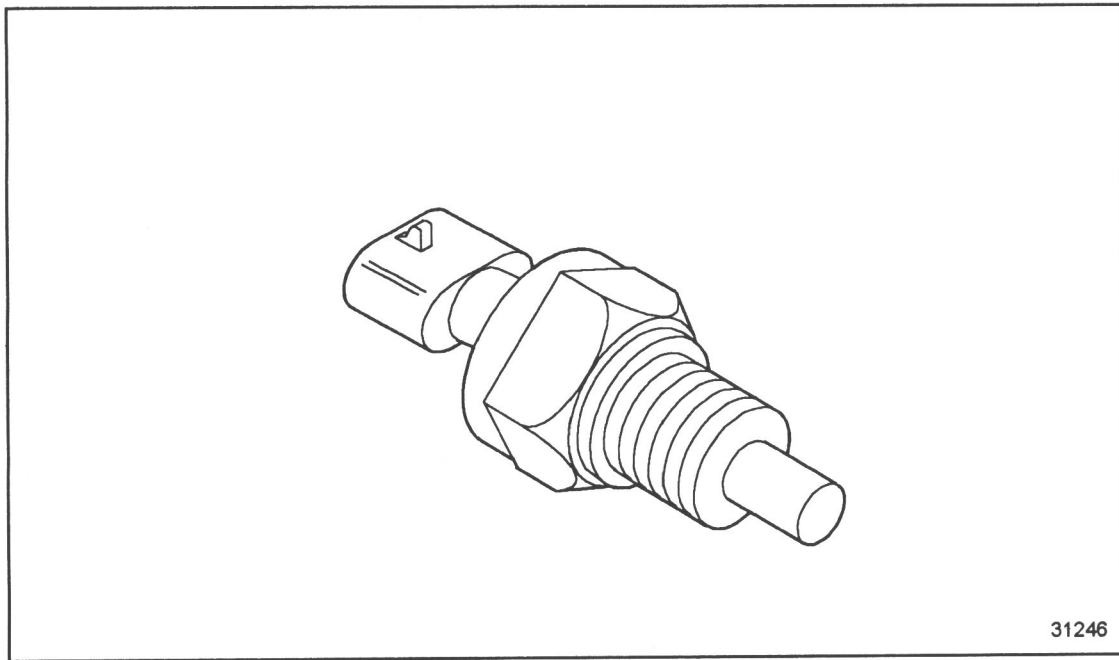

Figure 2-6 Oil and Fuel Temperature Sensors

2.3.8 Electronic Control Module

The ECM is the brain of the computer system, receiving electronic inputs from the operator as well as from the engine and vehicle mounted sensors. See Figure 2-7.

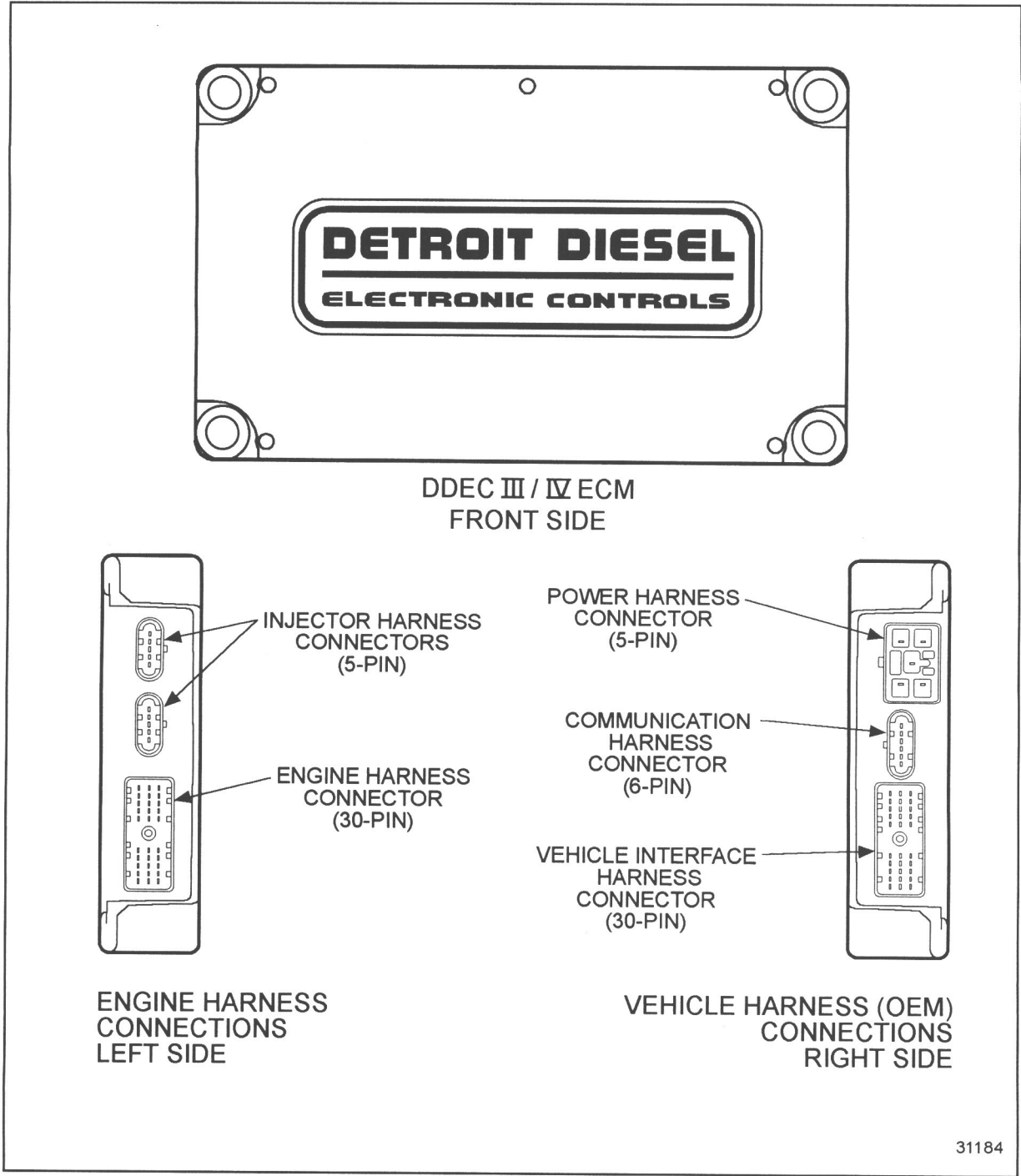

Figure 2-7 Electronic Control Module

2.3.9 Coolant Level Sensor

The engine protection feature will be triggered if the coolant level sensor detects a low coolant level. See Figure 2-8.

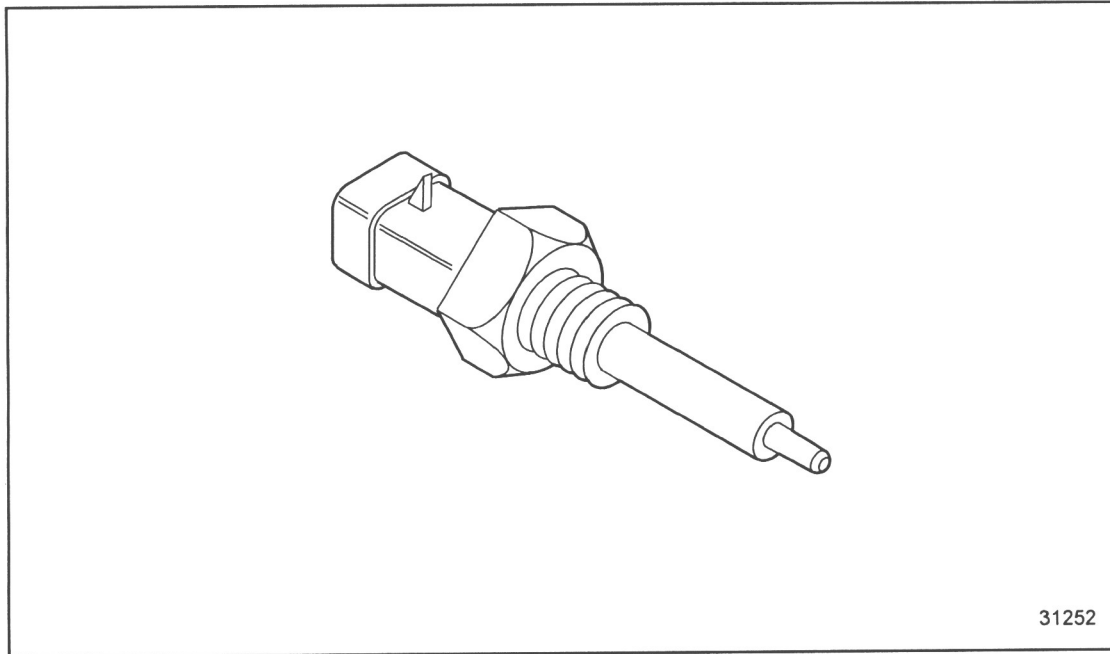

Figure 2-8 Coolant Level Sensor

2.3.10 Throttle Position Sensor

The electronic foot pedal assembly instantaneously converts the operator's throttle input into a signal to the ECM. The throttle response is fast and accurate. This sensor is self-calibrated, and requires no maintenance. See Figure 2-9.

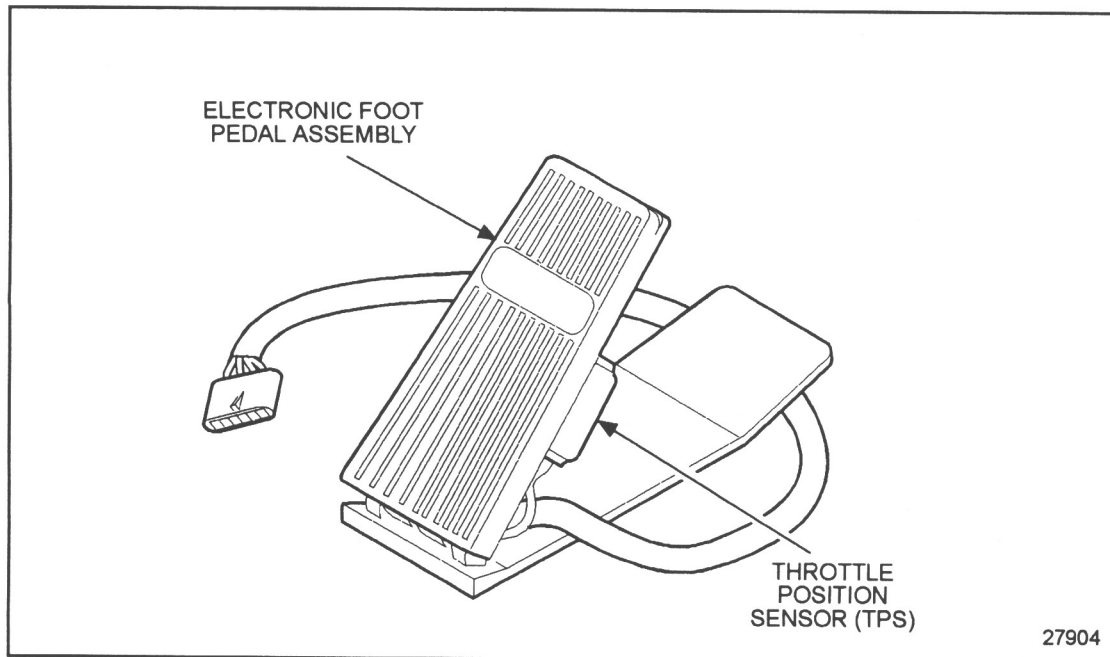

Figure 2-9 Throttle Position Sensor

2.3.11 Vehicle Speed Sensor

The vehicle speed sensor provides the ECM with the vehicle road speed for use with cruise control, vehicle speed limiting, and progressive shifting. See Figure 2-10.

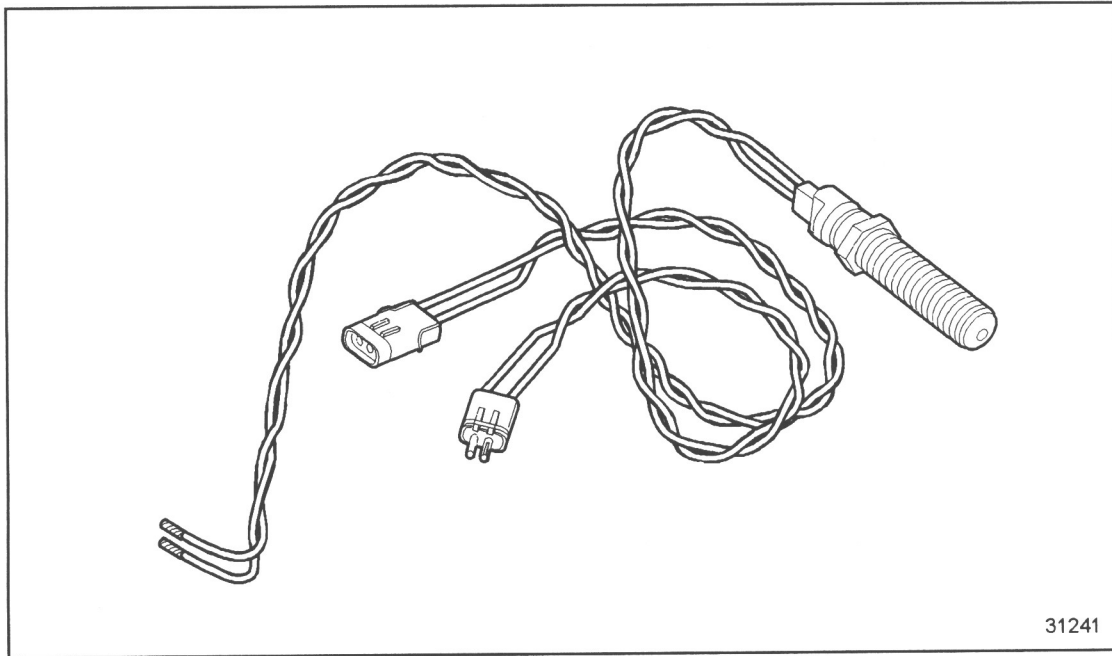

Figure 2-10 Vehicle Speed Sensor

2.3.12 Turbo Boost Sensor

In monitoring turbocharger compressor discharge, the turbo boost sensor provides air pressure data to the ECM for smoke control during engine acceleration. See Figure 2-11.

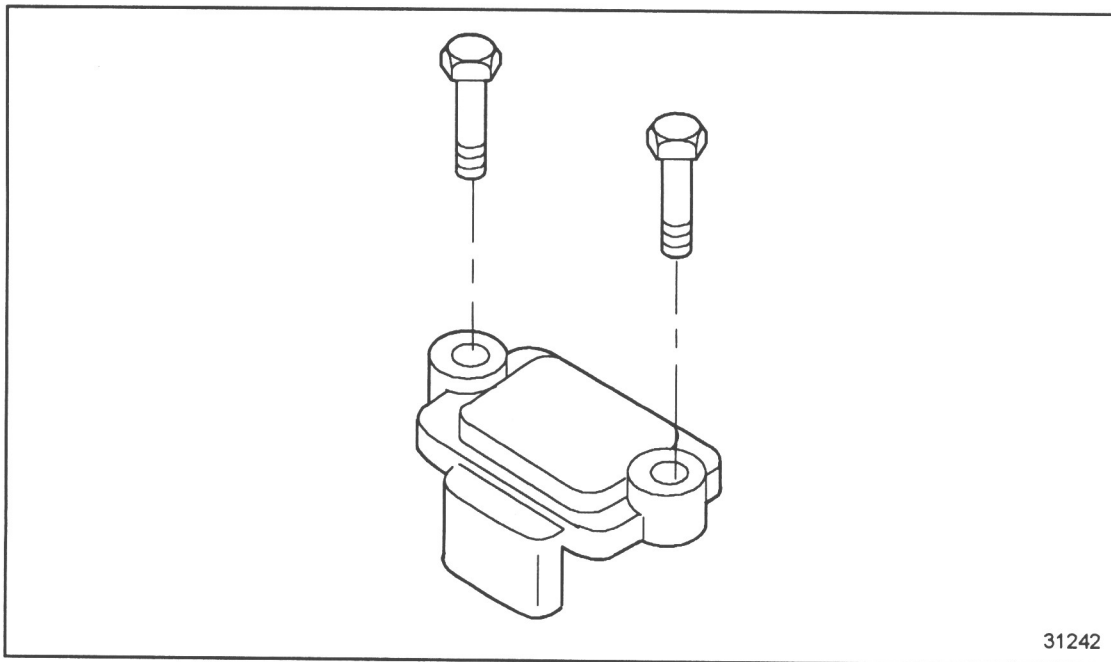

Figure 2-11 Turbo Boost Sensor

2.3.13 Oil Pressure Sensor

The oil pressure sensor will activate the engine protection system when the oil pressure falls below a normal oil pressure at a given engine r/min. See Figure 2-12.

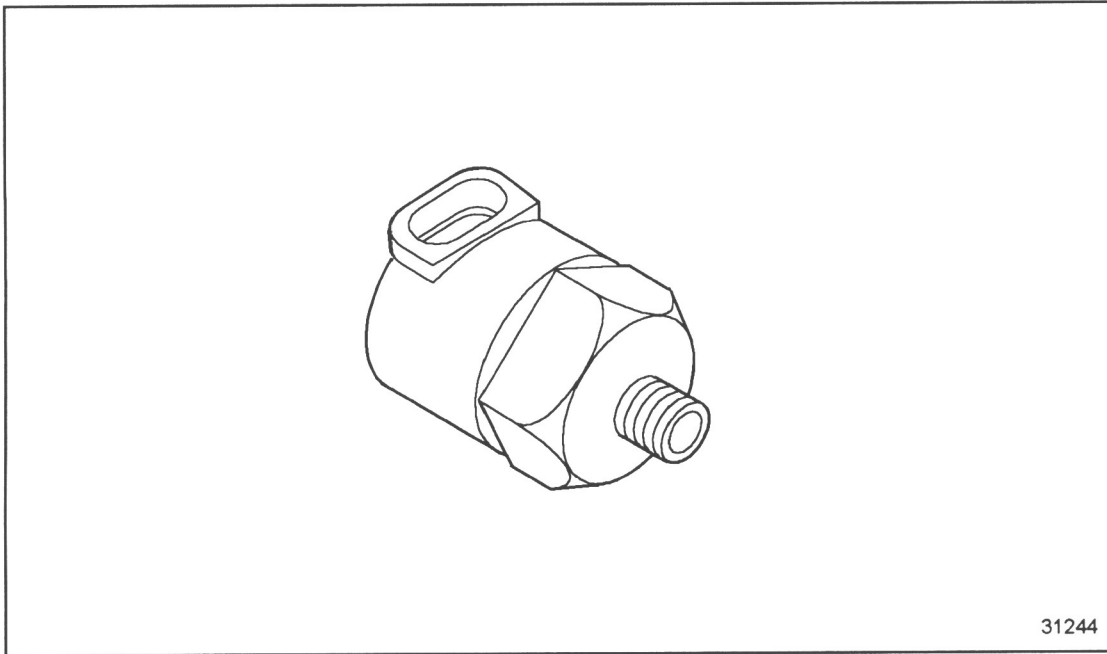

Figure 2-12 Oil Pressure Sensor

2.3.14 Fuel Pressure Sensor

The fuel pressure sensor monitors fuel pressure to warn the operator of impending power loss. This feature is optional. It is not used in international applications. See Figure 2-13.

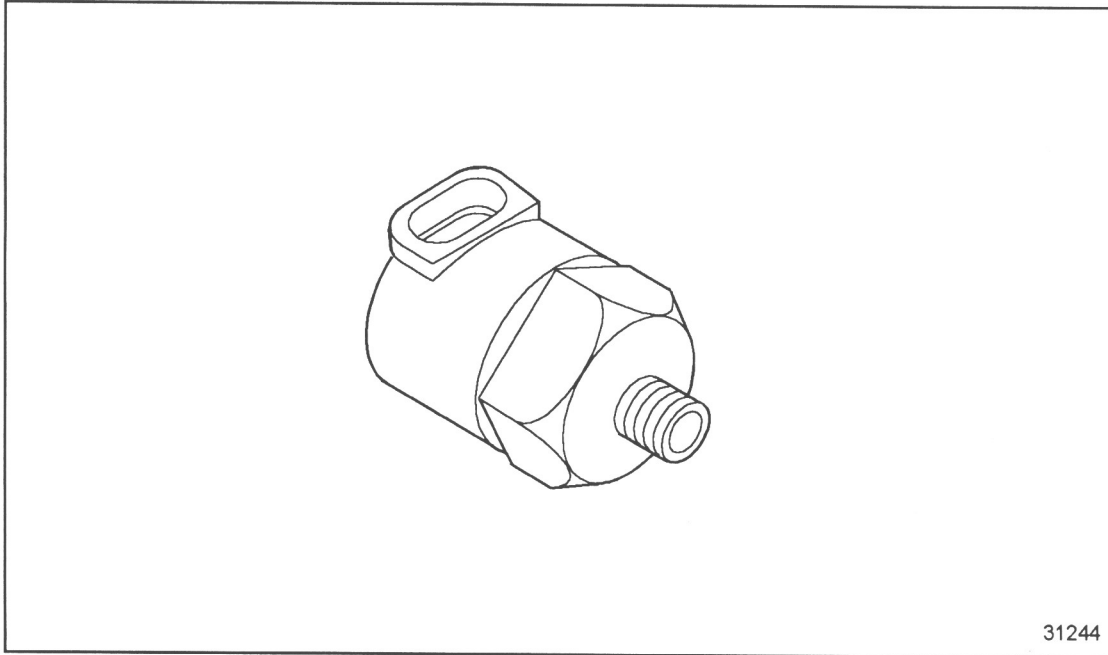

Figure 2-13 Fuel Pressure Sensor

2.4 DDEC RELATED PUBLICATIONS

The following manuals, listed in Table 2-1, should be used for reference when troubleshooting DDEC components.

Publication	Number
DDEC III Application and Installation manual	7SA800
Optimized Idle Installation and Troubleshooting	7SA734
Optimized Idle User Manual	6SE518
Optimized Idle Troubleshooting and Reprogramming	18SA366
Engine Synchro Shift (ESS) Troubleshooting Manual	6SE498
Construction and Industrial EDM and AIM Installation and Troubleshooting	7SA801
Construction and Industrial EDM and AIM User Manual	6SE710
DDC Ether Start	7SA727
Series 50G Application and Installation Engineering Guidelines, Bulletin 53	18SA365
DDEC III Automotive Code Chart, 3 color, 8.5 x 11	7SE444
DDEC III Codes, Reference Pamphlet	7SE414
DDEC II Troubleshooting Manual	6SE489
DDEC II Application and Installation manual	7SA707
Series 60 Driving Tips (includes VHS video)	25STV0161

Table 2-1 DDEC Related Publications

